



**Henry County Water Authority**

**COMMERCIAL DEVELOPMENT IMPACT FEE EVALUATION**  
 (Payment Required Prior to Permitting)

Landlord or Business Owner Contact Information	
<i>Name</i>	
<i>Mailing Address</i>	
<i>Phone Number</i>	
<i>E-Mail</i>	

Tenant / Business Information	
<i>Project Name</i>	
<i>Name of Business</i>	
<i>Service Address</i>	
<i>Tax ID #</i>	
<i>Type of Business</i>	
<i># of Employees</i>	
<i>If a Restaurant, Seating Capacity</i>	

Project Explanation

HCWA USE ONLY			
Fire Meter	Yes	No	If yes, 04" 06" 08" 10"
Domestic Meter	Yes	No	If yes, 3/4" 01" 02"
Irrigation Meter	Yes	No	If yes, 3/4" 01" 02"
Stubbed out	Yes	No	
Sewer	Yes	No	
Comments			

Scan and email to: [impactfees@hcwa.com](mailto:impactfees@hcwa.com)



Henry County Water Authority

## Impact Fee Agreement

This Agreement, made and entered into this \_\_\_\_ day of \_\_\_\_\_ 20\_\_\_\_, by and between the HENRY COUNTY WATER AUTHORITY (hereinafter called "Authority") and \_\_\_\_\_, who is the owner of the property located at \_\_\_\_\_ (hereinafter called "Owner").

WHEREAS, the Owner has requested water and/or sewer service; and  
WHEREAS, the Owner is subject to the Impact Fee Ordinance of the Authority; and  
WHEREAS, the Owner has requested that the Authority compute the initial water and/or sewer impact fees based on data provided by the Owner or based upon previous history of like or similar customers; and

WHEREAS, the Owner understands and agrees that an adjustment in the impact fees may be required;

NOW THEREFORE, for and in consideration of the mutual covenants hereinafter stated, it is agreed as follows:

1.

The method of computation of the initial impact fee is set forth by the Authority.

2.

If the consumption of service by the Owner is greater than that stated, the impact fees shall be adjusted according to the usage at the impact fee rate(s) in effect at the time of the new invoice and as set forth in the Impact Fee Ordinance.

3.

Owner agrees to pay all impact fees that are due.

4.

Owner hereby understands that impact fees shall be paid in full prior to issuance of a release letter; which is required to obtain a land disturbance permit, building permit or approval of Certificate of Occupancy.

5.

As set forth in the Impact Fee Ordinance, any future demand placed on the water and/or sewerage facilities in excess of the average demand anticipated at the time of issuance of the impact fee invoice shall be assessed.

IN WITNESS WHEREOF, the undersigned parties have set their hands and affixed their seals the day and year written above.

\_\_\_\_\_  
Signature

\_\_\_\_\_  
Print

Scan and email to: [impactfees@hcwa.com](mailto:impactfees@hcwa.com)



**Henry County Water Authority**  
Water Loss Department

Dear Commercial Customer,

Thank you for your meter purchase. Once your new water meter is set, you will be responsible for having the proper backflow device installed on your water service. There are two categories for commercial accounts, medium or high risk.

- Medium risk customers will be required to install a DCV (Double Check Valve) assembly in accordance with HCWA specifications. Examples of medium risk customers include offices, warehouses, and churches, etc. All commercial customers are considered medium risk, unless you fall into the high-risk category.
- High risk customers will be required to install a RPZ (Reduced Pressure Zone) assembly in accordance with HCWA specifications. Please note that **ALL** commercial irrigation is considered high risk and must have a RPZ installed. Examples of high-risk customers include medical facilities, car washes, and irrigation, etc.

If you are unsure which category you belong in, please contact us.

Following installation of the appropriate device, an initial test will be performed. Annual testing of these devices will be required hereafter in accordance with HCWA's Cross Connection Control Program. A CERTIFIED backflow tester approved by HCWA must complete the tests. This list can be found at [www.hcwa.com](http://www.hcwa.com). (A list of certified testers can be provided upon request.)

Successful test reports can be submitted by:

1. E-Mail: [backflow@hcwa.com](mailto:backflow@hcwa.com)
2. Fax: 678.583.2900
3. Mail: Cross Connection Control Program  
100 Westridge Industrial Blvd., McDonough, GA 30253.

*\*Referenced HCWA account number must be included on test report.*

Failure to comply with these requirements may result in suspension of your water service. If you have any questions, please call 678-583-3800 so that we may assist you.

HENRY COUNTY WATER AUTHORITY  
CROSS CONNECTION CONTROL PROGRAM

Signature \_\_\_\_\_ Date \_\_\_\_\_

Scan and email to: [impactfees@hcwa.com](mailto:impactfees@hcwa.com)

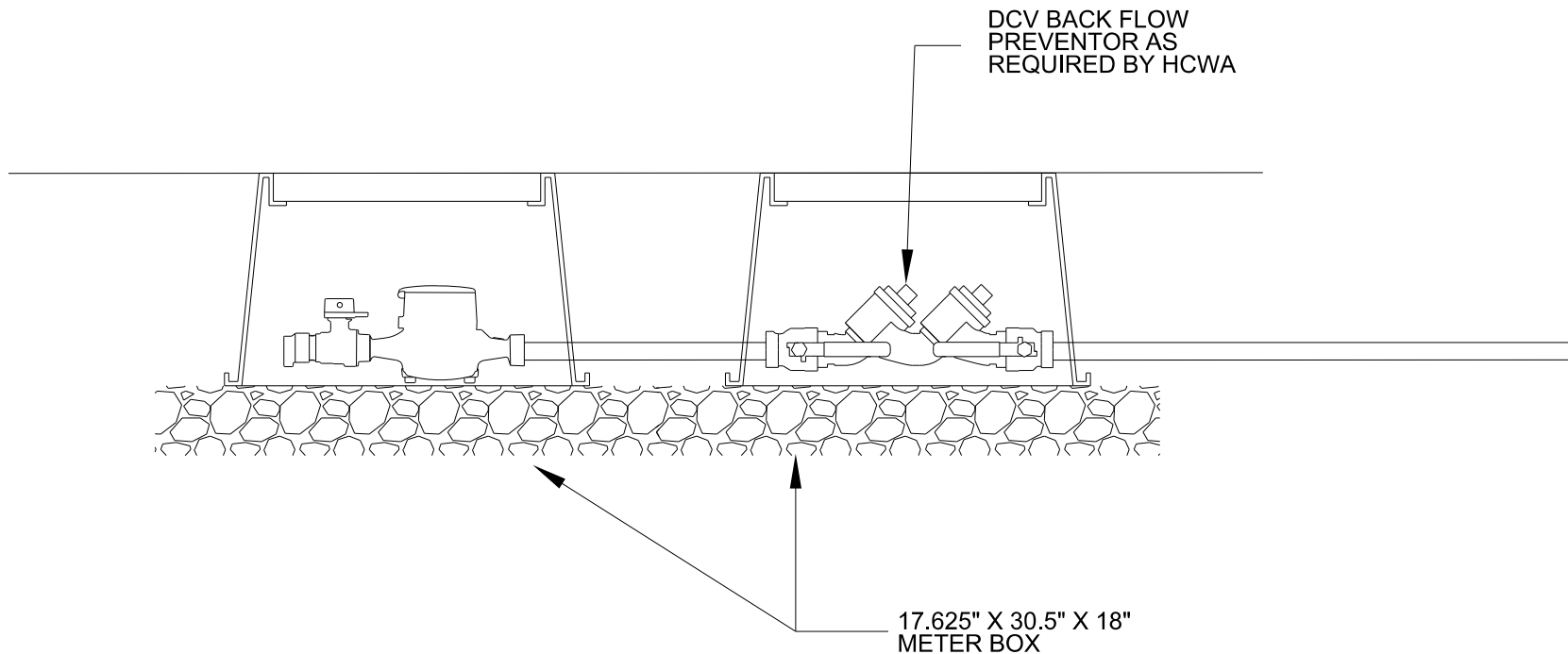

**NOTES:**

1. NO PERMANENT STRUCTURES SHALL BE ALLOWED WITHIN 5 FEET OF WATER SERVICE.
2. TYPICAL INSTALLATION MAY BE MODIFIED AT THE DISCRETION OF HCWA.



HENRY COUNTY WATER AUTHORITY

# DOUBLE CHECK VALVE DETAIL

REVISED: 04/07/2015

SCALE: N.T.S.

DETAIL NO.

**N/A**

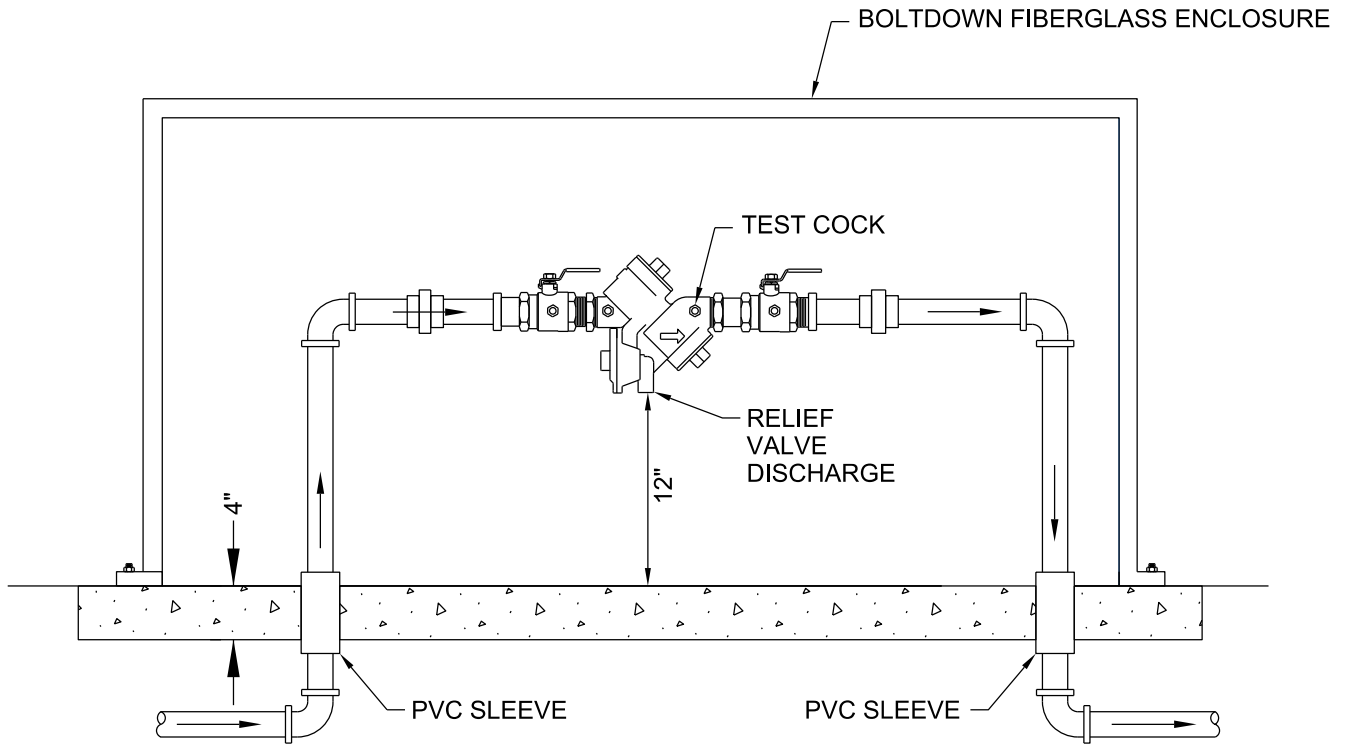

**NOTES:**

1. NO PERMANENT STRUCTURES SHALL BE ALLOWED WITHIN 5 FEET.
2. TYPICAL INSTALLATION MAY BE MODIFIED AT THE DISCRETION OF HCWA.
3. MINIMUM OF 4 TEST COCKS.



HENRY COUNTY WATER AUTHORITY

**REDUCED PRESSURE  
ZONE DETAIL**

REVISED: 11/13/2018

SCALE: N.T.S.

DETAIL NO.

**W26**